



AUTOMATIC PALLETIZING SYSTEMS

4.0 INDUSTRY
compliant

IoT ready



Automatic palletizing systems

» SMI palletizing systems set a new standard in the scenario of robotized palletizers equipped with two Cartesian axes.

SMI's APS series is the result of intense research and innovation, which has allowed us to implement technologically advanced systems that now offer each user the packaging solution best suited to his/her needs.

SMI palletizing systems are able to optimize the end-of-line operations of many industrial sectors: beverage production, agricultural and food, chemicals, pharmaceuticals, detergents, glass, paper and many others.

The APS series consists of automatic systems that palletize cardboard blanks, packets, trays, and packs in general.

By integrating the system main functions into the central column, SMI's palletizing systems are extremely compact and easily adaptable to any logistic condition of the end-of-line area, both in existing systems and in new installations.





SMI palletizing systems are able to optimize the end-of-line operations of many industrial sectors: beverage production, agricultural and food, chemicals, pharmaceuticals, detergents, glass, paper and many others.

» **Fast and accurate operations**

APS series palletizers are equipped with independent machine axes driven by electronically-controlled brushless motors, which ensure fast, smooth and accurate movements.

The use of this solution in the field of palletizing systems, characterized by repetitive actions, enables to achieve high reliability and reduce maintenance and running costs.

» **Innovative technology and ease of use**

Both machine automation and control rely on innovative technology based on Sercos fieldbus, through which the operator can quickly and easily manage all palletizing operations at the end of the line using a simple and user-friendly man-machine interface.

System management is made even easier by the use of advanced graphics, touch screens and a wide range of diagnostics and technical support available in real time.

The system's high degree of automation features low energy costs as well as low running and maintenance costs.

» **Guaranteed strength and reliability**

The accurate sizing of the column and the horizontal beam, combined with their sliding on recirculating ball runners, ensure fluid and continuous movements with minimal dynamic buckling and virtually no vibrations: this ensures a long lifecycle of the mechanical components.



» **Maximum safety at all times**

The range of SMI's APS series palletizers is equipped with a brand new dedicated "Safety PLC", which allows you to program the safety systems in a flexible, reliable and efficient manner.



The PLC monitors the proper operation of all the machine safety devices, integrating them together. It also allows the user to create custom protection areas within the perimeter of the palletizing system.

This significantly reduces machine downtime both in case of emergencies and during the loading operations of pallets, interlayer pads, etc., thanks to differentiated logics for the various areas of intervention.

As such, maintenance is easier and any adjustment to future safety standards will be faster and safer as they will be upgraded directly via the PLC's program.

» **Energy savings and reduced maintenance**

SMI's APS palletizing systems easily fit into existing or newly installed packaging lines and are immediately operational. By integrating multiple functions into just a few operating units, these systems are assembled, pre-wired and tested at the factory before delivery, hence minimizing assembly and start-up at the customer's facility. The system's high degree of automation, its mechanical simplicity, the use of robot-based components and its structural optimization allow a significant cut in maintenance costs and reduction in energy consumption, as well as the extension of the system's life cycle.



	FEATURES	SPEED*
APS 615 APS 620	ULTRA-COMPACT PALLETIZERS	15 PPM / 60 LPH 20 PPM / 60 LPH
APS 1540 APS 1570	LAYER FORMATION WITH 90°PRODUCT INFEEED	40 PPM / 120 LPH 70 PPM / 200 LPH
APS 3070 L APS 3105 L	MANIPULATOR-EQUIPPED IN-LINE LAYER PRE-COMPOSITION/S	70 PPM / 200 LPH 105 PPM / 300 LPH
APS 4140 L	TWO-COLUMN PALLETIZING SYSTEM	140 PPM 400 LPH

*Max speed referred to columnar pattern 21 (no pack rotation), 3 x 2 packs, 1.5 L bottles. (PPM: packs per minute - LPH: layers per hour)



UP TO 15 PPM*

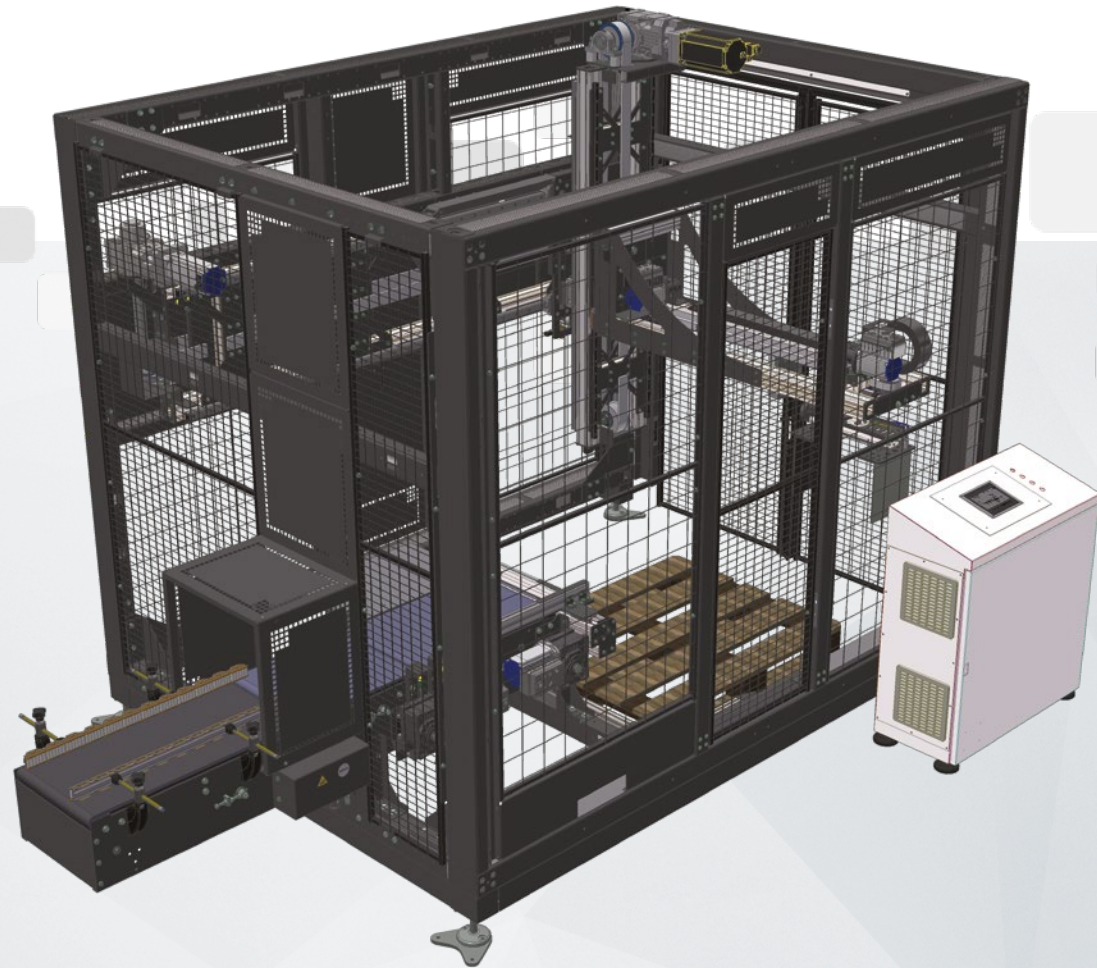

» Semi-automatic compact palletizer

APS 615 is an ultra-compact palletizer, suitable for low speed production plants, that stands out for its easy installation, management and maintenance.

The core of this semi-automatic palletizing system is composed of the structure in which the three Cartesian axis system, performing the pallet formation, is positioned. It is added to the infeed conveyor, the product picking head and the machine guards.

At the palletizer infeed, the product arrives at the product feeding conveyor and is cadenced by a rubber conveyor.

Later, it is brought into the picking position by a distancing conveyor, where the gripping head picks the pack, individually or grouped, and places it on the pallet fed by specific roller conveyors. The cyclic repetition of this operation enables to form several palletizing layers. The full pallet is moved to the unloading area and, at the same time, at the infeed, in the formation area, a palletizing feeding system positions a new empty pallet, so that a new palletizing cycle can start. This model aims at meeting the requirements of customers with reduced production needs and budgets (small wine cellars, craft breweries, lines with manual loading, etc.).

» Main features

- Production output up to 15 packs/minute (60 layers/hour), referred to columnar pattern 21 (non-rotated packs), 3x2 packs, 1.5 L bottles.
- Handled pallets: 800x1200 mm and 1000x1200 mm europallets (other formats upon request).
- Layer composition through side gripping, vacuum or magnetic head.
- Pack rotation is performed by the motorized gripping head.
- The pad-inserting device is available as an option at extra charge; the loading of the pads into the magazine is performed manually by the machine operator.

*Max speed referred to columnar pattern 21 (no pack rotation), 3 x 2 packs, 1.5 L bottles. (PPM: packs per minute - LPH: layers per hour)



Standard configuration

» Product feeding conveyor

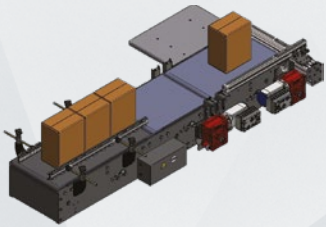

The product arriving at the palletizer is cadenced by the rubber conveyor. The distancing conveyor moves the product to the picking position (depending on the product size and palletizing pattern

required, even more products can be accumulated on the picking conveyor). If the palletizing pattern needs to pick more packs, the latter are brought by a cylinder into an additional station and then picked by the gripping head.

» Product gripping head

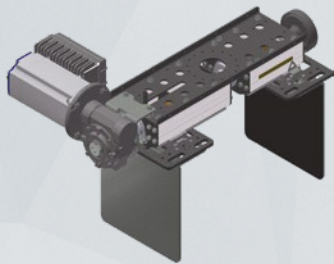

These palletizers can be equipped with two different gripping heads: in particular, depending on the user's production needs, a side gripping head or a vacuum gripping head can be installed. The first one is ideal for any type of

pack and involves the movement of the product picking rubber paddles by means of two cylinders. The second one is ideal for boxes and involves the movement of the products by means of vacuum generators (the number of the latter depends on the size of the pack processed). The gripping head is equipped with a motor for the product rotation, so that the pack is placed on the layer in the position required by the palletizing pattern.

» Machine guards



Net guards installed directly on the machine edge: the pallet load/unload is performed by a double-swing door equipped with a safety lock with electromagnet.



Optional devices

» Pad-inserting device

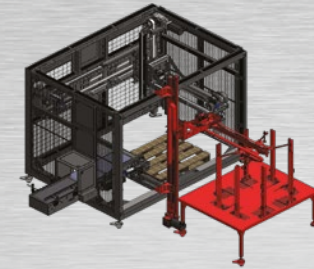

The pad-inserting module is a pad feeding system adjustable according to the different size of the interlayer pad, that can be matched to the structure of the palletizer. The suction-cup gripping system with 4 adjustable lifting points ensures the accurate lifting of any kind of interlayer pad. The loading of the pads into the magazine is performed manually by the machine operator.

» Additional door



A second side access door can be added as an optional device to facilitate possible interventions on the cadence conveyor and on the pallet.



UP TO 20 PPM*

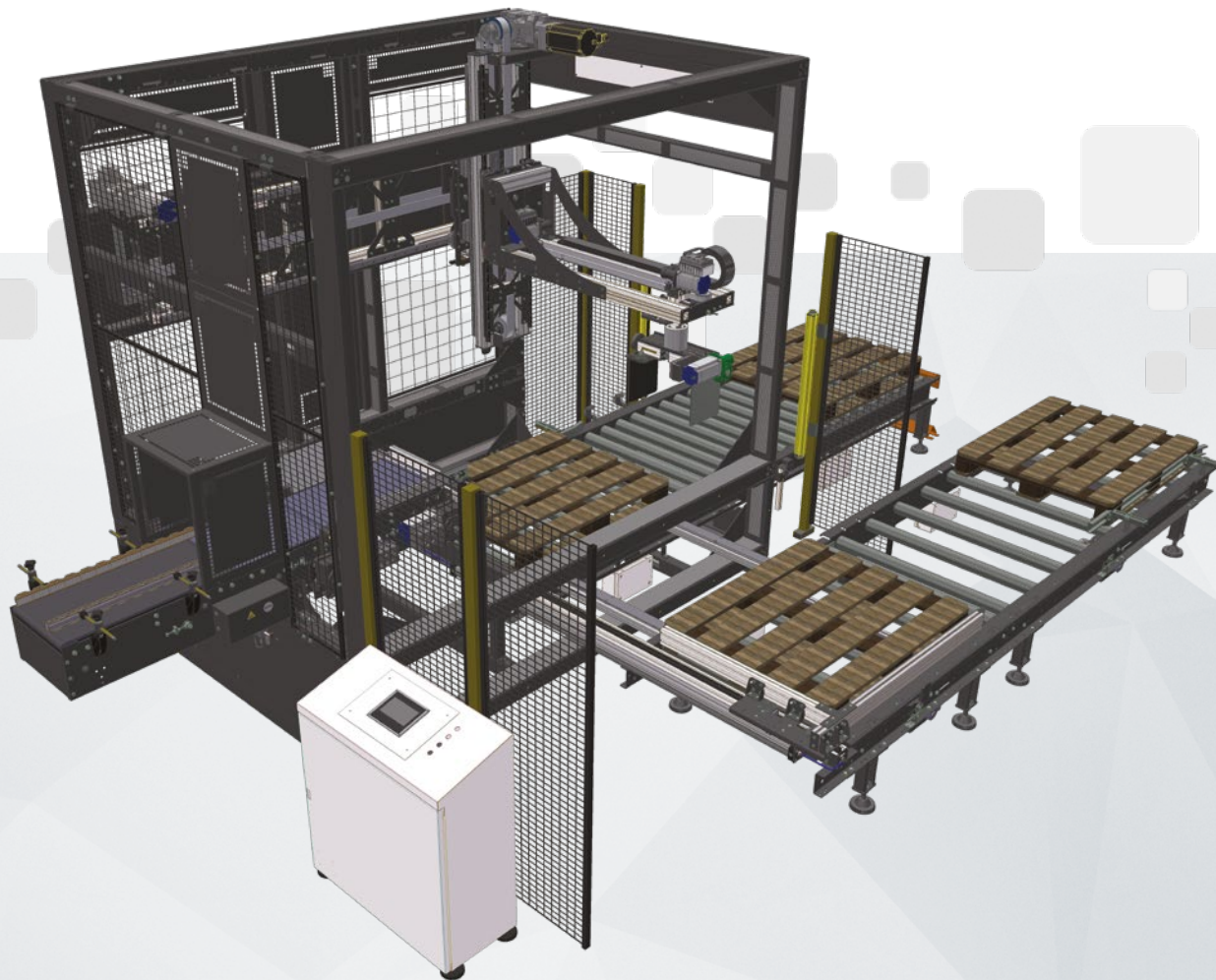

» Automatic compact palletizer

APS 620 is an ultra-compact palletizer, suitable for low speed production plants, that stand out for its easy installation, management and maintenance.

The core of this semi-automatic palletizing system is composed of the structure in which the three Cartesian axis system, performing the pallet formation, is positioned.

It is added to the infeed conveyor, the product picking head, the pallet feeding line and the machine guards.

At the palletizer infeed, the product arrives at the product feeding conveyor and is cadenced by a rubber conveyor.

Later, it is brought into the picking position by a distancing conveyor, where the gripping head picks the pack, individually or grouped, and places it on the pallet fed by specific roller conveyors.

The cyclic repetition of this operation enables to form several palletizing layers. The pallet feeding is performed by motorized rollers; once the pallet has been completed, the system brings it to the unloading area and, at the same time, it places a new empty pallet in the formation area.

The full pallet is moved to the unloading area and, at the same time, at the infeed, in the formation area, a palletizing feeding system positions a new empty pallet, so that a new palletizing cycle can start.

» Main features

- Production output up to 20 packs/minute (60 layers/hour), referred to columnar pattern 21 (non-rotated packs), packs 3x2, 1.5 L bottles.
- Handled pallets: 800x1200 mm and 1000x1200 mm euro pallet (other formats upon request).
- Layer formation through side gripping head.
- Pack rotation is performed by the motorized gripping head.
- The pad-inserting device is available as an option at extra charge; the loading of the pads into the magazine is performed manually by the machine operator.

*Max speed referred to columnar pattern 21 (no pack rotation), 3 x 2 packs, 1.5 L bottles. (PPM: packs per minute - LPH: layers per hour)

Standard configuration

» Product feeding conveyor

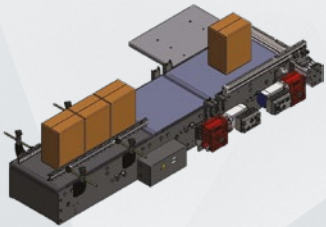

The product arriving at the palletizer is cadenced by the rubber conveyor. The distancing conveyor moves the product to the picking position (depending on the product size and palletizing pattern required, even more products can be accumulated on the picking conveyor). If the palletizing pattern needs to pick more packs, the latter are brought by a cylinder into an additional station and then picked by the gripping head.

» Pallet feeding system



The empty pallet, after having been loaded in the position external to the nets, is automatically brought into the pallet formation area. The pallet 90° transfer is ensured by a pneumatic device (Devio), that, moves the pallet to the desired position thanks to a cylinder. The full pallet is moved to the roller conveyor that is positioned outside the perimeter guards, where it is picked. This solution ensures fast pallet changeover times and minimizes the machine downtime.

» Product gripping head

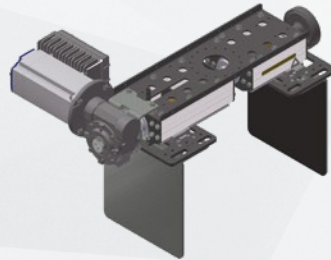

The system is equipped with a motorized side gripping head, composed of two rubber side paddles (one fixed and one motorized), that ensures an optimal grip for every type of product to be palletized. Furthermore, the gripping head is equipped with a motor for the product rotation, so that the pack is placed on the layer in the position needed by the palletizing pattern.

» Machine guards



Net guards installed in the machine, except for the pallet loading/unloading area, in which it is instead fixed to the floor. There are a discharge for the passage of the pallet to the empty pallet loading area and light curtains with muting device for the full pallet outfeed area.



Optional devices

» Pad-inserting device

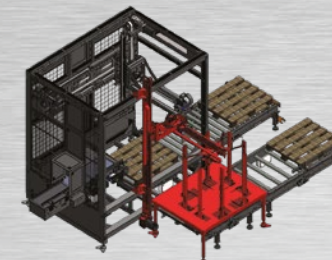

The pad-inserting module is a pad feeding system adjustable according to the different size of the interlayer pad, that can be matched to the structure of the palletizer. The suction-cup gripping system with 4 adjustable points ensures the accurate lifting of any kind of interlayer pad. The loading of the pads into the magazine is performed manually by the machine operator.

» Additional door



Empty pallet magazine with integrated roller conveyor is available as an optional device. The maximum storage capacity of this device is about 300 kg (12 1000x1200 mm pallets).





UP TO 40 PPM*



» Fixed column with loading head

The APS 1540 is made up of a single-column palletizing system with two Cartesian axes, with bottom-up movements.

The vertical axis consists of a fixed column on which the horizontal beam slides on recirculating ball guides; the loading head slides horizontally on said beam, always on recirculating ball guides.

The beam's vertical movements and the horizontal ones of the head-holder are driven by brushless motors, which ensure perfect trajectories during all palletizing phases.

» Main features

- Compact layout: the central column is equipped with a loading head (basket) moving along two Cartesian axes
- Layer formation with 90° product infeed
- Pre-assembled modules for easy and fast assembly and start-up
- Smooth movements of the horizontal beam on recirculating ball skids
- Independent machine axes controlled by brushless motors for fast and precise movements
- Independent pallet magazine for pallet feeding
- Independent layer-inserting device for layer feeding (optional)

- Maximum output rate of 40 packs per minute (120 layers / hour), referred to columnar pattern 21 (no pack rotation), 3 x 2 packs, 1.5 L bottles
- Pallets handled: europallet 800x1200 mm and 1000x1200 mm (other formats upon request)
- Layer formation by loading head (basket), which eliminates pattern workability limits
- Pack rotation (accessory on sale) occurs by pneumatic contrast
- The interlayer pad-inserting device is an accessory on sale: the new version enables to load directly the whole pallet of pads (the pallet has to comply with specific tolerances)

*Max speed referred to columnar pattern 21 (no pack rotation), 3 x 2 packs, 1.5 L bottles. (PPM: packs per minute - LPH: layers per hour)



Standard configuration

» Single-entry infeed with 90° layer-forming system

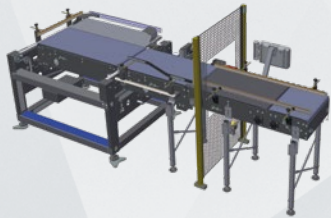

Single-entry infeed with 90° layer-forming system equipped with: 1 rubberized cadencing belt, 1 product infeed belt, in order to form the row and 1 one-way translation system that contributes to forming the layer into the basket. The layer-forming system

is equipped with energy-efficient motors. Designed in accordance with FCR (Full Cost Reduction) methodologies, it is tested and supplied to the client fully assembled and cabled. Start-up time is really short, since it consists in connecting the connected cable of signals and power of sercos fieldbus to the central module of APS palletizing system. The ergonomic and functional structure of the frame allows the operator to easily carry out all the operations related to the use and maintenance of the plant.

» Row transfer device

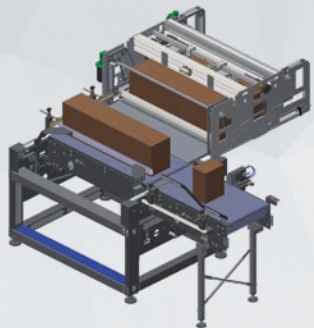

The row transfer process is managed by a motorized bar. After a row is formed, it gets pushed straight away into the loading head (basket). The system is equipped with a "dead" plate (buffer), which enables to continue with the row push-in operations even when the head is not yet in the loading position.

» Empty pallet magazine

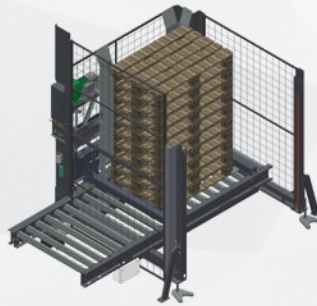

- **Standard:** 1 pile of empty pallets
Maximum height: 1800 mm
Pile maximum weight: 300 kg
- **Optional:** stackable pallet magazine, suitable for very heavy pallets (up to 700 kg)

» Pallet roller conveyor



Frame in painted steel and rollers with 76 mm ø 150 mm pitch, motorised through a 5/8 inch chain. Electronically reversible central motorization. The system is tested in SMI factory and is supplied to the client fully assembled and cabled. Available in different lengths: 1500 mm, 2000 mm, 2500 mm and 3000 mm.



Optional devices

» Pack rotation devices

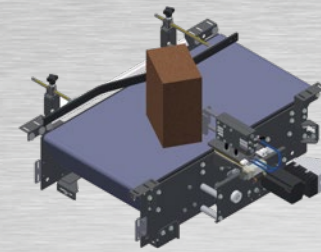

This optional system allows to turn packs being fed to the palletizer by means of a contrast cylinder. If packs get to the machine with the short side leading, a second optional cylinder is available to ease the rotation process.

» Layer-inserting device

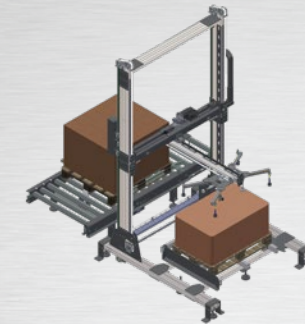

The pad-inserting module is a pad feeding system adjustable in accordance with the size of the interlayer pad, that can be combined with the central column of the APS ERGON palletizer. Suction-cup gripping system from 4 up to 8 adjustable points to ensure the accurate lifting of any kind of interlayer. The interlayer pad automatic loading is available as optional and allows to load the pallet of interlayer pads without stopping the machine (through the addition of one station for loading pallets of interlayer pads and one station for unloading empty pallets).





UP TO 70 PPM*

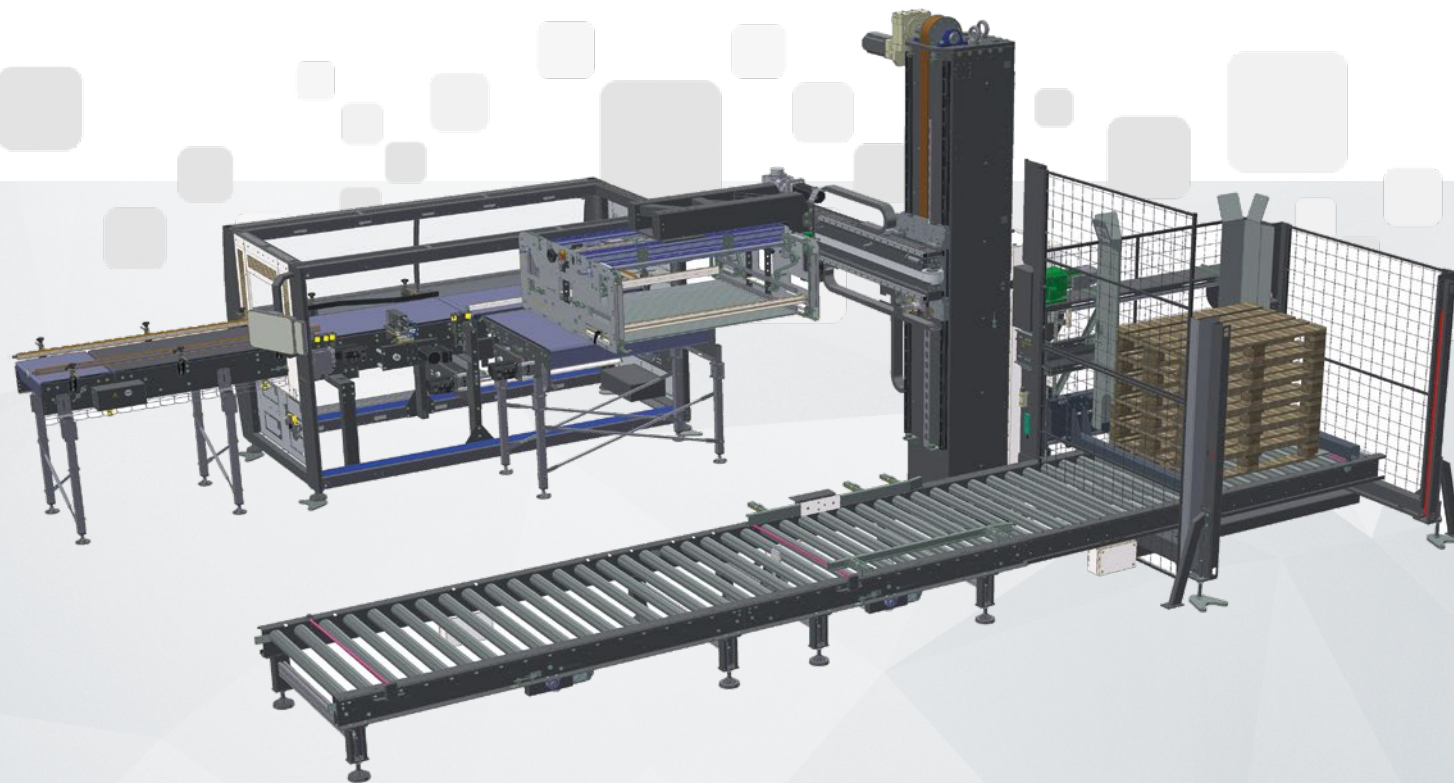

» Fixed column with loading head

The APS 1570 is made up of a single-column palletizing system with two Cartesian axes, with bottom-up movements.

The vertical axis consists of a fixed column on which the horizontal beam slides on recirculating ball guides; the loading head slides horizontally on said beam, always on recirculating ball guides.

The beam's vertical movements and the horizontal ones of the head-holder are driven by brushless motors, which ensure perfect trajectories during all palletizing phases.

» Main features

- Compact layout: the central column is equipped with a loading head (basket) moving along two Cartesian axes
- Layer formation with 90° product infeed
- Pre-assembled modules for easy and fast assembly and start-up
- Smooth movements of the horizontal beam on recirculating ball skids
- Independent machine axes controlled by brushless motors for fast and precise movements
- Independent pallet magazine for pallet feeding
- Independent layer-inserting device for layer feeding (optional)

- Maximum output rate of 70 packs per minute (200 layers / hour), referred to columnar pattern 21 (no pack rotation), 3 x 2 packs, 1.5 L bottles
- Pallets handled: europallet 800x1200 mm and 1000x1200 mm (other formats upon request)
- Layer formation by loading head (basket), which eliminates pattern workability limits
- Pack rotation occurs by pneumatic contrast or by motorized manipulator (accessory on sale)
- The interlayer pad-inserting device is an accessory on sale; the new version enables to load directly the whole pallet of pads (the pallet has to comply with specific tolerances)

*Max speed referred to columnar pattern 21 (no pack rotation), 3 x 2 packs, 1.5 L bottles. (PPM: packs per minute - LPH: layers per hour)

Standard configuration

» Single-entry infeed with 90° layer-forming system

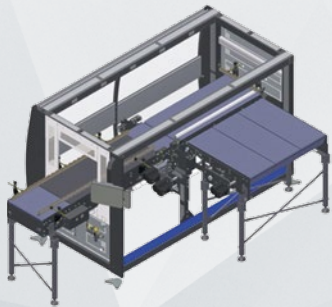

Single-entry infeed with 90° layer-forming system equipped with: 1 rubberized cadencing belt, 1 product infeed belt, in order to form the row and 1 one-way translation system that contributes to forming the layer into the basket. The layer-forming system is equipped with energy-efficient motors. Designed

in accordance with FCR (Full Cost Reduction) methodologies, it is tested and supplied to the client fully assembled and cabled. Start-up time is really short, since it consists in connecting the connected cable of signals and power of sercos fieldbus to the central module of APS palletizing system. The ergonomic and functional structure of the frame allows the operator to easily carry out all the operations related to the use and maintenance of the plant.

» Row transfer device

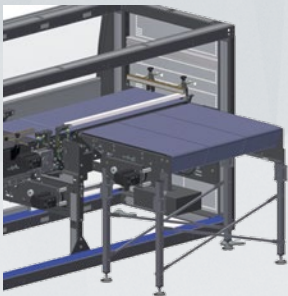

The row transfer process is managed by a motorized bar. After a row is formed, it gets pushed straight away into the loading head (basket). The system is equipped with a "dead" plate (buffer), which enables to continue with the row push-in operations even when the head is not yet in the loading position.

» Empty pallet magazine

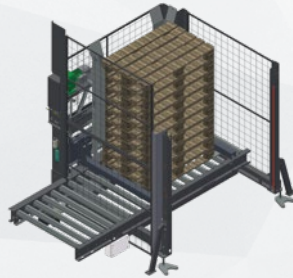

- **Standard:** 1 pile of empty pallets
Maximum height: 1800 mm
Pile maximum weight: 300 kg
- **Optional:** stackable pallet magazine, suitable for very heavy pallets (up to 700 kg)

» Pallet roller conveyor



Frame in painted steel and rollers with 76 mm ø 150 mm pitch, motorised through a 5/8 inch chain. Electronically reversible central motorization. The system is tested in SMI factory and is supplied to the client fully assembled and cabled. Available in different lengths: 1500 mm, 2000 mm, 2500 mm and 3000 mm.



Optional devices

» Pack rotation devices

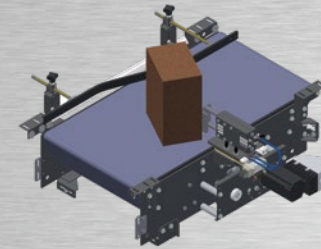

This optional system allows to turn packs being fed to the palletizer by means of a contrast cylinder. If packs get to the machine with the short side leading, a second optional cylinder is available to ease the rotation process.

» Motorized manipulator

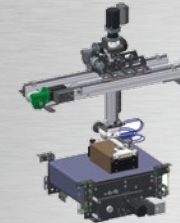

On the APS 1570 pack rotation can also be carried out by a motorized manipulator (optional device).

» Layer-inserting device

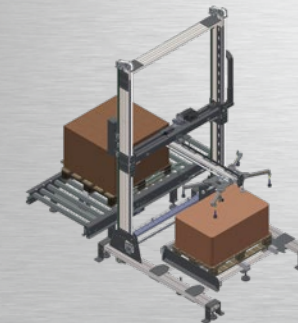

The pad-inserting module is a pad feeding system adjustable in accordance with the size of the interlayer pad, that can be combined with the central column of the APS ERGON palletizer. Suction-cup gripping system from 4 up to 8 adjustable points to ensure the accurate lifting of any kind of interlayer. The interlayer pad automatic loading is available as optional and allows to load the pallet of interlayer pads without stopping the machine (through the addition of one station for loading pallets of interlayer pads and one station for unloading empty pallets).



UP TO 70 PPM*

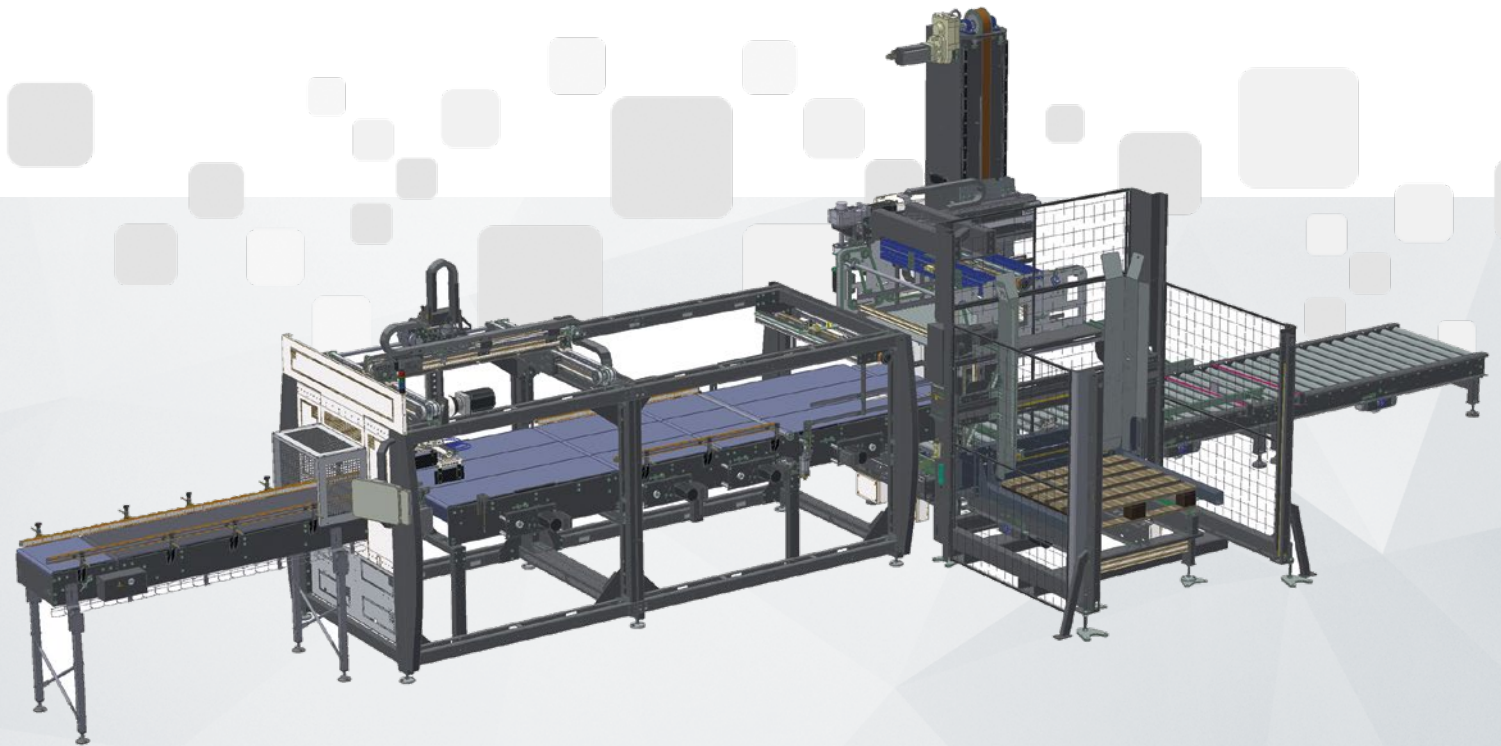

» Fixed column with loading head

The APS 3070 L is made up of a single-column palletizing system with two Cartesian axes, with bottom-up movements. The vertical axis consists of a fixed column on which the horizontal beam slides on recirculating ball guides; the loading head slides horizontally on said beam, always on recirculating ball guides. The beam's vertical movements and the horizontal ones of the head-holder are driven by brushless motors, which ensure perfect trajectories during all palletizing phases.

» Main features

- Compact layout: the central column is equipped with a loading head (basket) moving along two Cartesian axes
- Continuous layer-forming system with one motorized manipulator
- Pre-assembled modules for easy and fast assembly and start-up
- Smooth movements of the horizontal beam on recirculating ball skids
- Independent machine axes controlled by brushless motors for fast and precise movements
- Independent pallet magazine for pallet feeding
- Independent layer-inserting device for layer feeding (optional)
- Pallets handled: europallet 800x1200 mm and 1000x1200 mm (other formats upon request)
- The interlayer pad-inserting device is an accessory on sale; the new version enables to load directly the whole pallet of pads (the pallet has to comply with specific tolerances)

*Max speed referred to columnar pattern 21 (no pack rotation), 3 x 2 packs, 1.5 L bottles. (PPM: packs per minute - LPH: layers per hour)

Standard configuration

» In-line layer pre-forming infeed

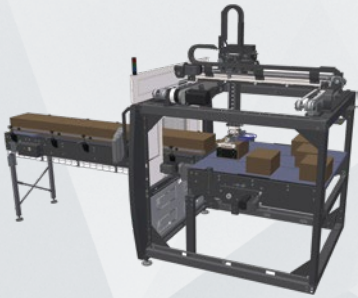

By means of an innovative system of pack rotation and/or manipulation in continuous motion on three Cartesian axes (x, y and z), bundles coming along a belt in single (APS 3070 L) or double (APS 3105 L e 3140 L) lane are turned, shifted and arranged onto

multiple lanes according to the palletizing pattern, thus pre-forming the layer. A special mechanical actuator separates the pre-formed layer from the accumulating bundles, while the manipulation system prepares the next layer. The layer thus formed is smoothly conveyed into the basket as it exploits the motion of the belt and does not require mechanical layer-translation elements. The continuous layer-forming infeed allows to streamline end-of-line space management. This new system distinguishes itself for its one-way motion and for the possibility to arrange the bundles in whichever position. The layer-forming system is equipped with sliding safety guards in anodised aluminium featuring a rounded shape which let all the motors (featuring low energy consumption) be placed externally if compared to the mechanical groups they activate. The closing system of safety guards is equipped with a slow-down device, which accompanies them smoothly in their final phase of closure. The ergonomic and functional frame enables the operator to carry out easily all activities related to use and maintenance of the installation. Accident-prevention protections are made of aluminium and lucid polycarbonate (PC) in compliance with EC regulations.

» Empty pallet magazine



- **Standard:** 1 pile of empty pallets
- Maximum height:** 1800 mm
- Pile maximum weight:** 300 kg
- **Optional:** stackable pallet magazine, suitable for very heavy pallets (up to 700 kg)

» Pallet roller conveyor



Painted steel frame. Rollers with 76 mm Ø and 150 mm pitch, motorized through a 5/8 inch chain. Electronically reversible central motorization. The system is controlled by the main electrical cabinet. Designed in accordance with FCR (Full Cost Reduction) it is tested and supplied to the customer completely mounted and cabled.



Optional devices

» Layer-inserting device

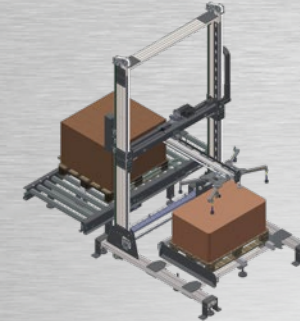

The pad-inserting module is a pad feeding system adjustable in accordance with the size of the interlayer pad, that can be combined with the central column of the APS ERGON palletizer. Suction-cup gripping system from 4 up to 8 adjustable points to ensure the accurate lifting of any kind of interlayer. The interlayer pad automatic loading is available as optional

and allows to load the pallet of interlayer pads without stopping the machine (through the addition of one station for loading pallets of interlayer pads and one station for unloading empty pallets).





UP TO 105 PPM*

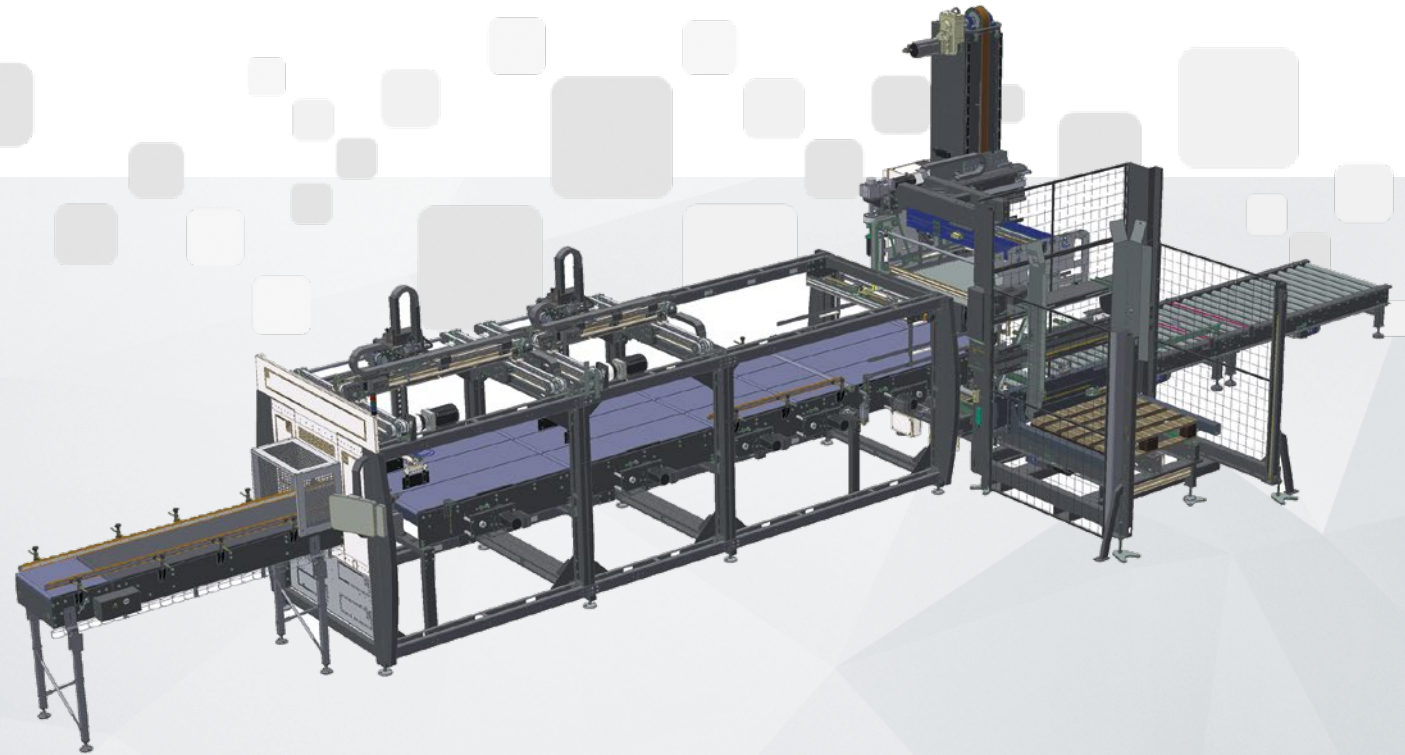

» Fixed column with loading head

The APS 3105 L is made up of a single-column palletizing system with two Cartesian axes, with bottom-up movements. The vertical axis consists of a fixed column on which the horizontal beam slides on recirculating ball guides; the loading head slides horizontally on said beam, always on recirculating ball guides. The beam's vertical movements and the horizontal ones of the head-holder are driven by brushless motors, which ensure perfect trajectories during all palletizing phases.

» Main features

- Compact layout: the central column is equipped with a loading head (basket) moving along two Cartesian axes
- Continuous layer-forming system with two motorized manipulators
- Pre-assembled modules for easy and fast assembly and start-up
- Smooth movements of the horizontal beam on recirculating ball skids
- Independent machine axes controlled by brushless motors for fast and precise movements
- Independent pallet magazine for pallet feeding
- Independent layer-inserting device for layer feeding (optional)
- Pallets handled: europallet 800x1200 mm and 1000x1200 mm (other formats upon request)
- The interlayer pad-inserting device is an accessory on sale; the new version enables to load directly the whole pallet of pads (the pallet has to comply with specific tolerances)

*Max speed referred to columnar pattern 21 (no pack rotation), 3 x 2 packs, 1.5 L bottles. (PPM: packs per minute - LPH: layers per hour)

Standard configuration

» In-line layer pre-forming infeed



By means of an innovative system of pack rotation and/or manipulation in continuous motion on three Cartesian axes (x, y and z), bundles coming along a belt in single (APS 3070 L) or double (APS 3105 L e 3140 L) lane are turned, shifted and arranged onto multiple lanes according to the palletizing pattern, thus pre-forming the layer. A special mechanical actuator separates the pre-formed layer from the accumulating bundles, while the manipulation system prepares the next layer. The layer thus formed is smoothly conveyed into the basket as it exploits the motion of the belt and does not require mechanical layer-translation elements. The continuous layer-forming infeed allows to streamline end-of-line space management. This new system distinguishes itself for its one-way motion and for the possibility to arrange the bundles in whichever position. The layer-forming system is equipped with sliding safety guards in anodised aluminium featuring a rounded shape which let all the motors (featuring low energy consumption) be placed externally if compared to the mechanical groups they activate. The closing system of safety guards is equipped with a slow-down device, which accompanies them smoothly in their final phase of closure. The ergonomic and functional frame enables the operator to carry out easily all activities related to use and maintenance of the installation. Accident-prevention protections are made of aluminium and lucid polycarbonate (PC) in compliance with EC regulations.

» Empty pallet magazine



- **Standard:** 1 pile of empty pallets
Maximum height: 1800 mm
Pile maximum weight: 300 kg
- **Optional:** stackable pallet magazine, suitable for very heavy pallets (up to 700 kg)

» Pallet roller conveyor



Painted steel frame. Rollers with 76 mm Ø and 150 mm pitch, motorized through a 5/8 inch chain. Electronically reversible central motorization. The system is controlled by the main electrical cabinet. Designed in accordance with FCR (Full Cost Reduction) it is tested and supplied to the customer completely mounted and cabled.



Optional devices

» Layer-inserting device

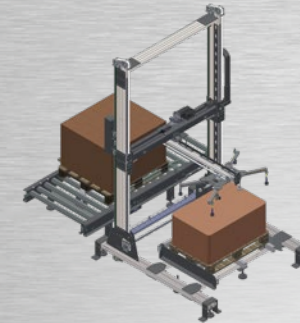

The pad-inserting module is a pad feeding system adjustable in accordance with the size of the interlayer pad, that can be combined with the central column of the APS ERGON palletizer. Suction-cup gripping system from 4 up to 8 adjustable points to ensure the accurate lifting of any kind of interlayer. The interlayer pad automatic loading is available as optional

and allows to load the pallet of interlayer pads without stopping the machine (through the addition of one station for loading pallets of interlayer pads and one station for unloading empty pallets).





UP TO 140 PPM*

» Two-column system

The APS 4140 is a compact palletizer, equipped with two independent columns that perform the vertical movement for palletizing different types of packs and is composed of pre-wired modules, configurable in a personalized way.

The core of the system is composed of two vertical columns: the first equipped with a motorized belt and the second with a basket. This is combined with a product infeed module with layer preformation system, pallet module, safety guards and pad-insertion module (optional).

» Main features

- Compact layout: two columns for the pallet formation, the first with belt and the second with loading head (basket); the movement of both of them takes place on the vertical axis
- Infeed equipped with a continuous layer preformation system with two manipulators
- Pre-wired modules for easy and fast assembly and start up
- Smooth movements of the vertical axis on ball recirculation skids
- Independent machine axes controlled by brushless motors, for fast and precise movements
- Independent pallet magazine for pallet feeding
- Independent pad-inserting device for pad feeding (optional)
- Handled pallets: 800x1200 mm and 1000x1200 mm europallets (other formats upon request)
- The pad-inserting device is an accessory for sale: the new version enables to load directly the entire pad pallet (the pallet has to comply with certain tolerances)



*Max speed referred to columnar pattern 21 (no pack rotation), 3 x 2 packs, 1.5 L bottles. (PPM: packs per minute - LPH: layers per hour)

Standard configuration

» Operating principle and infeed with layer pre-formation

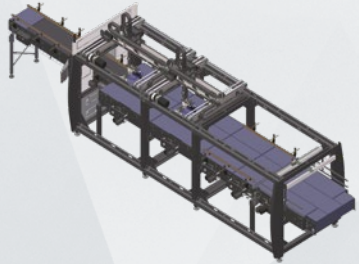

Differently from traditional palletizers, where a single column generally performs two movements (vertical and horizontal), this model is equipped with two independent columns that execute

only the vertical movement (the first column is equipped with a motorized belt, while the second with a basket). The first column receives the complete layer from the infeed module and, moving only on the vertical axis, brings the product to the height of the basket of the second column: from here the layer is placed into the basket by the motorized belt. At this point, the basket places the layer on the pallet; after that, moving on the vertical axis only, it goes back to its position waiting for the following layer. Thanks to an innovative pack rotation and/or manipulation system, the packs arriving at the conveyor on single/double lane are turned, translated and placed on more rows in the position required by the palletizing pattern. The infeed is very compact and allows to optimize the end-of-line space.

» Empty pallet magazine

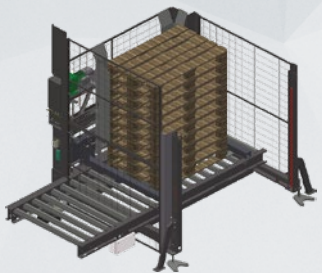

- **Standard:** 1 column of empty pallets
Max. height: 1800 mm
Max. stack weight: 300 kg
- **Optional:** stackable pallet magazine, for very heavy pallets (up to 700 kg)



Optional devices

» Pad-inserting device



- Independent pad-inserting device with gantry structure
- Possibility to load directly the entire pad pallet, provided that it complies with the alignment constraints required by the machine

- **Pad automatic loading (optional):** it allows to load the pad pallet without stopping the machine (through the addition of a station for the pad pallet loading and a station for the empty pallet unloading)

» Device "inserting the first pad"

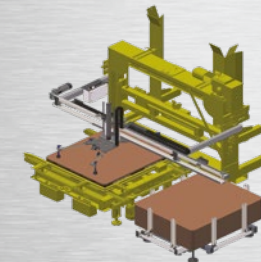

With high machine cycles, in case the pad is needed not only between the layers, but also on the pallet, the new accessory "inserting the first pad" is required.

This is a small pad-inserting device with

the task of picking the pad from a magazine (manual loading) and placing it on the pallet before it arrives at the pallet formation area; this enables to use the traditional pad-inserting device for the management of the pads between the layers.

Differently from traditional pad-inserting systems, whose movements are controlled by motors, this device is equipped with a cylinder for the execution of the vertical movement.

Packposer

The Packposer divider-laner receives the packs coming from the packer positioned upstream and, by means of an innovative manipulation system based on three Cartesian axes (x, y and z) and equipped with a motorized gripper, turns them and/or arranges them on two or more lanes, thus composing the format of repackaging set by the packaging machine's work program positioned downstream. The divider is made of top-quality materials, ensuring operational reliability and long-term duration. The use of wear-resistant components minimizes the maintenance and cleaning operations, thus reducing the total operating costs.



Packsorter

The Packsorter divider-laner receives the packs in single lane coming from the packer positioned upstream and, by means of an innovative manipulation system based on three Cartesian axes (x, y and z), arranges them on two or more lanes and conveys them toward the automatic palletization system positioned downstream.

The divider can receive also packs in double lane, thus working simply as a conveyor toward the palletizer.

The divider is made of top-quality materials, ensuring operational reliability and long-term duration.

The use of wear-resistant components minimizes the maintenance and cleaning operations, thus reducing the total operating costs.

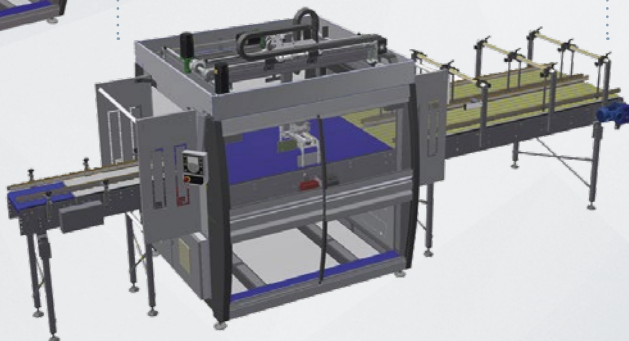

Automation

SMI manufactures advanced technology palletizers, featuring modular design, operating flexibility and high-energy efficiency, thanks to fully automatic processes, electronically controlled drive shafts and field bus wiring.

The hardware and software components are "open" and modular, in compliance with the most important international certifications and rely upon consolidated standards of the industrial field and of the packaging sector: OMAC guidelines (Open Modular Architecture Controls), Sercos, PROFIBUS, IEC61131, OPC, Industrial PC.

In particular, by following the OMAC guidelines and the Omac Packaging Workgroup (OPW), SMI can guarantee easy integration with the other machines in line, user-friendly technology and maintenance of the investment value.

Moreover, SMI systems comply with the technical requirements of Industry 4.0 and IoT (Internet of Things) technologies, which allow to easily and effectively run production lines within a "Smart Factory", even remotely through mobile devices.



The automation and control system of SMI machines, called MotorNet System®, includes the following hardware components: MARTS (process controller), POSYC® (man-machine interface), COSMOS (digital servodriver for brushless motors), dGATE and aGATE (remote IP65 I/O digital/analogic modules).

The MARTS is a PAC (Programmable Automation Controller), based on an industrial PC, which can be programmed in IEC61131 languages. The COSMOS servodrivers and the dGATE/aGATE I/O modules are connected to the PAC via sercos.

The POSYC® is a HMI terminal, (touch screen IP65), based on an industrial PC with solid state drives.



MotorNet System®



SMART BOTTLING & PACKAGING LINES UP TO 50,000 BOTTLES/HOUR

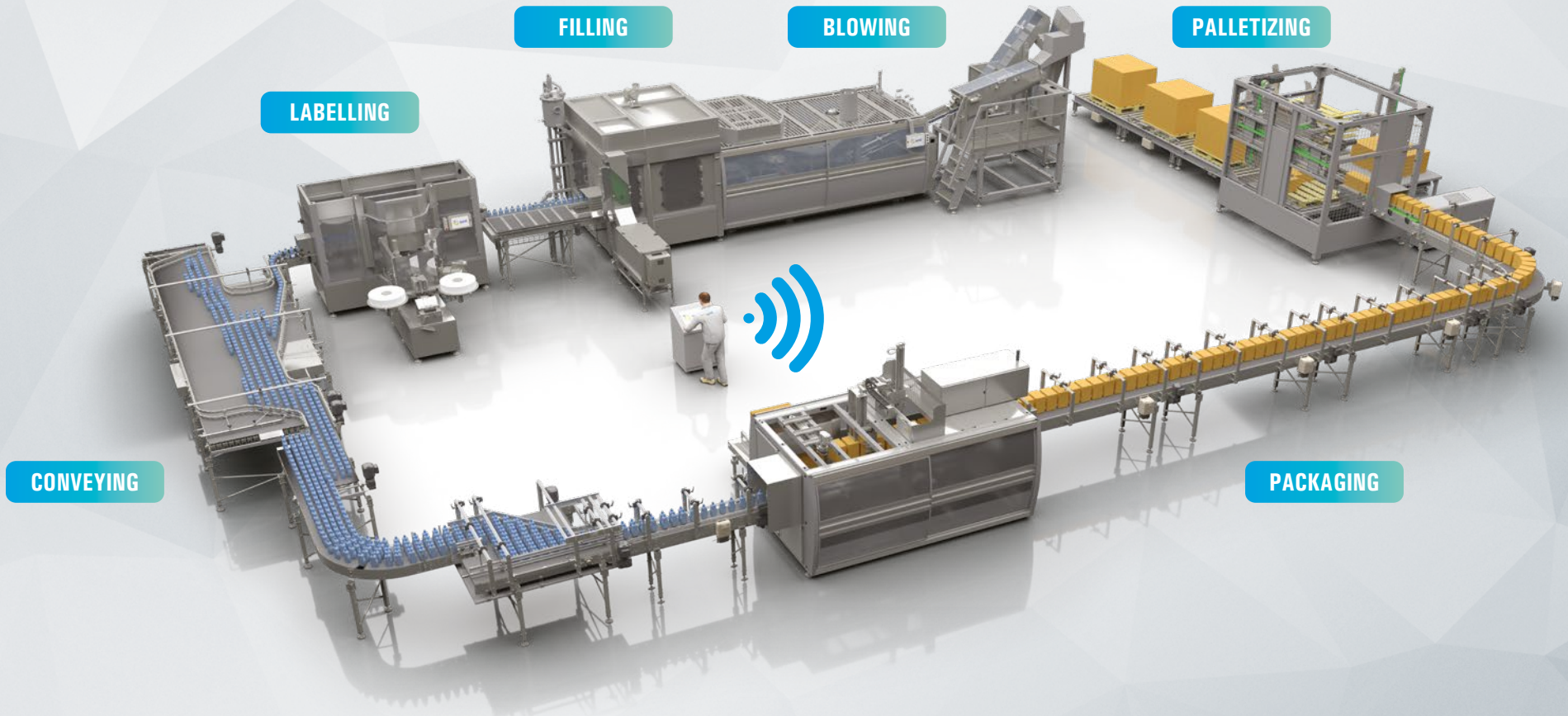



www.smigroup.it



SMI S.p.A.
Via Carlo Ceresa, 10
I-24015 San Giovanni Bianco (BG)
Tel.: +39 0345 40.111
Fax: +39 0345 40.209
E-mail: info@smigroup.it

